

Read the operating instructions prior to commissioning

Operating instructions

Griddle plate, griddle pan

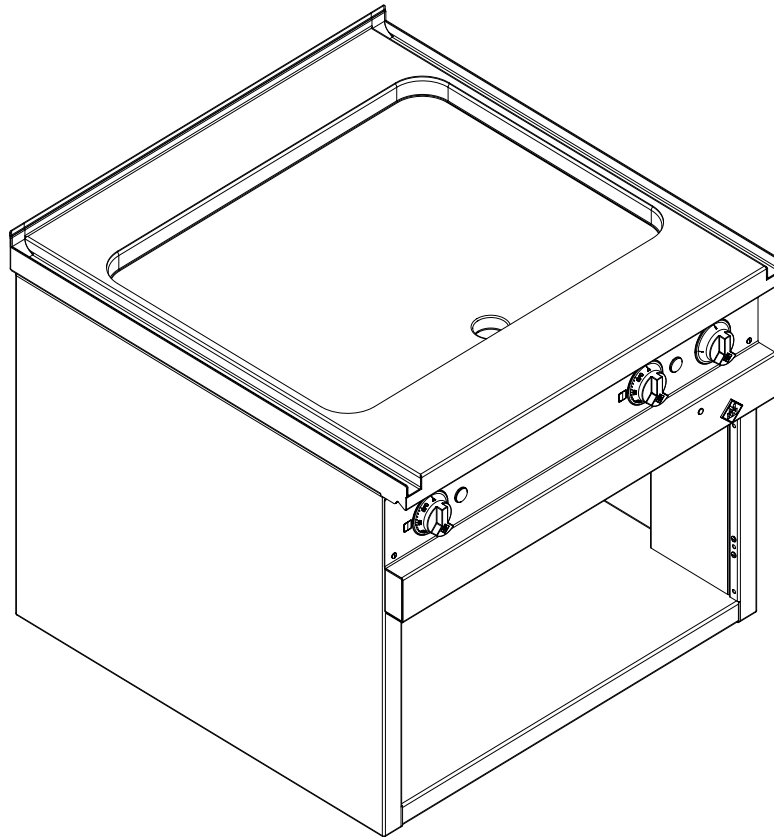

Translation from the original document • 2021126-21ABBE-D • 15/01/2018

Unit	Type of energy	Model	
Griddle plate, griddle pan	Electric	OPEGRP... OPEGPF... O7EGRP... O7EGPF... HLEGRP... HLEGPF...	SLEGRP... SLEGPF... CVEGRP... CVEGPF... OIEGRP... OIEGPF...

2021126-21ABBE-D

en-GB

Operating and display elements

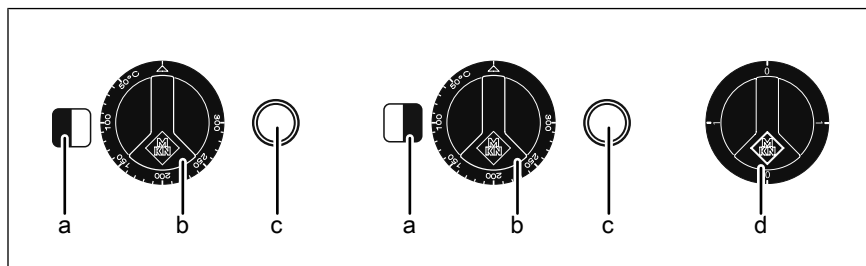

a *Heat zone identification*
b *Temperature control knob*

c *Heating indicator light*
d *On/Off control knob*

Manufacturer

MKN Maschinenfabrik Kurt Neubauer GmbH & Co. KG
Halberstädter Strasse 2a
38300 Wolfenbüttel
Germany

Phone +49 5331 89-0
Fax +49 5331 89-280
Internet www.mkn.eu

Copyright

All rights to text, graphics and pictures in this documentation are held by MKN Maschinenfabrik Kurt Neubauer GmbH & Co. KG. Distribution or duplication is only permitted with the prior written consent of MKN.

Copyright by MKN Maschinenfabrik Kurt Neubauer GmbH & Co. KG.



1 Introduction	7
1.1 About this manual	7
1.1.1 Explanation of signs	8
1.2 Intended use	9
1.3 Warranty	9
2 Safety information	10
3 Description of the unit	13
3.1 Overview of the unit	13
3.1.1 Floor-standing unit	13
3.1.2 Countertop unit	13
3.1.3 Suspended unit	14
3.2 Function of the operating and display elements	14
3.3 Operating temperature	14
4 Operating the unit	15
4.1 Switching the unit on and off	15
4.1.1 Switching on	15
4.1.2 Switching off	15
4.2 Basic functions	15
4.2.1 Set the temperature	15
4.3 Burning-in a frying surface made of steel	15
4.4 Frying	16
4.5 Braising	16
4.6 Emptying the collection container	17
4.7 Pausing and end of use	17
4.7.1 Short pause	17
4.7.2 Longer pause and end of use	17
5 Cleaning and caring for the unit	18
5.1 Preventing corrosion	18
5.1.1 Protecting a frying surface made of steel	18
5.2 Removing rust spots	19
5.3 Cleaning the housing	19
5.4 Cleaning the frying surface between cooking processes	19
5.5 Cleaning the frying surface	20
5.6 Cleaning the drain	20
5.7 Cleaning the collection container	21
6 Troubleshooting	22
6.1 Cause of failure and the remedy	22
6.2 Nameplate	22
7 Carrying out maintenance	23

8 Disposal in an environmentally responsible manner ...	24
9 Manufacturer's declaration	25

1 Introduction

1.1 About this manual

The operating instructions are part of the unit and contain information:

- On safe operation,
- On cleaning and care,
- On remedies in case of faults.

Be aware of the following notes and adhere to them:

- Read the operating instructions completely before operating the unit for the first time.
- Make the operating instructions available to the operator at all times at the operating site of the unit.
- Insert any supplements from the manufacturer.
- Keep the operating instructions throughout the service life of the unit.
- Pass on the operating instructions to any subsequent operator of the unit.

Target group The target group of the instruction manual is the operator, who is entrusted with the operation, cleaning and care of the unit.

Figures All figures in this manual are intended as examples. Discrepancies between these and the actual unit can arise.

1.1.1 Explanation of signs



DANGER
Imminent threat of danger

Failure to comply will lead to death or very severe injuries.



WARNING
Possible threat of danger

Failure to comply can lead to death or very severe injuries.



CAUTION
Dangerous situation

Failure to comply can lead to slight or moderately severe injuries.

ATTENTION
Physical damage

Failure to comply can cause physical damage.



Notes for better understanding and operation of the unit.

Symbol / sign	Meaning
•	Listing of information.
→	Action steps, which can be performed in any sequence.
1. 2.	Action steps, which must be performed in the specified sequence.
↳	Result of an action performed or additional information about it.

1.2 Intended use

This unit is intended to be used solely for commercial purposes, particularly in commercial kitchens.

This unit may only be used with suitable accessories and for the cooking of food.

It is forbidden to use the unit for purposes, which include the following:

- Heating acids, alkaline solutions or other chemicals
- Heating of warmer plates, containers and tins
- Drying cloths, paper or dishes
- Heating rooms
- As set-down area or working surface

The use of the unit is prohibited in the following countries:

1.3 Warranty

The warranty is void and safety is no longer assured in the event of:

- Improper conversion or technical modifications of the unit,
- Improper use,
- Incorrect startup, operation or maintenance of the unit,
- Problems resulting from failure to observe these instructions.

2 Safety information

The unit complies with applicable safety standards. Residual risks associated with operation or risks resulting from incorrect operation cannot be ruled out and are mentioned specifically in the safety instructions and warnings.

The operator must be familiar with regional regulations and observe them.

Operation During operation, the following group of individuals must be supervised by an individual who is responsible for safety:

- Individuals with physical, sensory, or mental handicaps, or who lack the knowledge and experience to operate the unit properly.

The supervising individual must be familiar with the unit and the risks associated with it.

Hot surfaces Risk of burns from hot surfaces

- Protect arms and hands by wearing suitable protective gloves.
- Do not touch heating elements, hot surfaces or accessories immediately after use.
- Allow surfaces to cool prior to cleaning.

Hot liquids Risk of burns from hot liquids

- Protect arms and hands by wearing suitable protective gloves.
- Observe the maximum filling quantity.

Risk of scalding from hot oil

- Protect arms and hands by wearing suitable protective gloves.
- Do not operate the unit without the receiver tank.

Risk of chemical burns from evaporating cleaners

- Follow the instructions of the cleaning agent manufacturer.

Defective unit Risk of injury from a defective unit

- Disconnect a defective unit from the electric mains.
- Do not operate a defective unit.
- Allow only an authorized technician to repair the unit.

Fire prevention Risk of fire from dirt and grease deposits

- Clean the unit when finished using it.
- Do not use the unit as a deep fat fryer.

Risk of fire from overheating

- Observe the unit during operation.

Firefighting

- In the event of a fire, disconnect the unit from the electric mains.
- Use a Fire Class F fire extinguisher, never water, to extinguish grease fires. Other fires, for instance, can be extinguished with fire extinguishers suitable for Fire Classes A, B, C, CO₂ fire extinguishers or extinguishing media suitable for the fire class confronted.

Unit on casters Risk of injury from a unit on casters

- Attach units with a wall side narrower than 600 mm to the wall at the installation site.
- Move the unit only for cleaning or maintenance.
- Lock casters during operation.
- Only move an empty unit.

Risk of a line breaking if subjected to high tensile load

- Secure the unit with a chain as a strain relief for the power connection at the installation site so that no tensile load is applied to the power connection if the unit is moved.

Improper cleaning Risk of chemical burns from cleaning agent

- Follow the instructions of the cleaning agent manufacturer.
- Take appropriate protective measures when handling aggressive cleaning agents.

Risk of falling on smooth floors

- Keep the floor in front of the unit clean and dry.

Risk of physical damage from improper cleaning

- Clean the unit after using it.
- Do not clean the unit with a high-pressure cleaner or water jet.
- Do not clean the housing with highly abrasive or chemically aggressive cleaning agents.
- Do not clean the housing with highly abrasive sponges.
- Follow the instructions of the cleaning agent manufacturer.
- Do not shock cool the unit, for example with ice, iced water or water.
- Use only a stainless steel scraper or stainless steel spatula for cleaning.
- Do not use any bleaching or chlorine-containing cleaners or disinfectants.
- Do not immerse the housing in water.

Hygiene Health risk from insufficient hygiene

- Observe applicable regional hygiene regulations.
- Follow the cleaning instructions.
- Observe food processing regulations when keeping food warm.

Improper use Risk of physical damage from improper use

- Do not operate the unit outdoors.
- Use only original accessories.
- Train operators regularly.
- Do not heat food warmer plates or tins of preserved food.
- Observe the unit during operation.
- Do not use the frying surface as a heating surface for pots.
- Use appropriate cooking utensils.

3 Description of the unit

3.1 Overview of the unit

3.1.1 Floor-standing unit

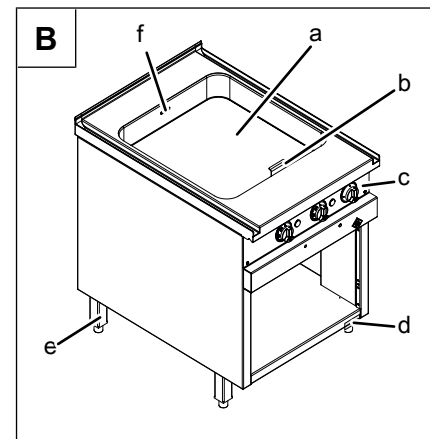
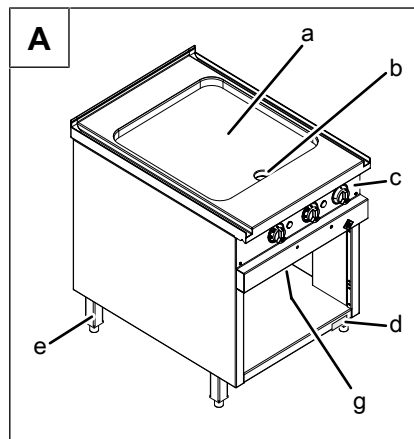

Image: A Griddle plate, B Griddle pan

- a Frying surface
- b Drain
- c Control panel
- d Nameplate

- e Equipment leg
- f *Maximum fill level mark*
- g Collection container

3.1.2 Countertop unit

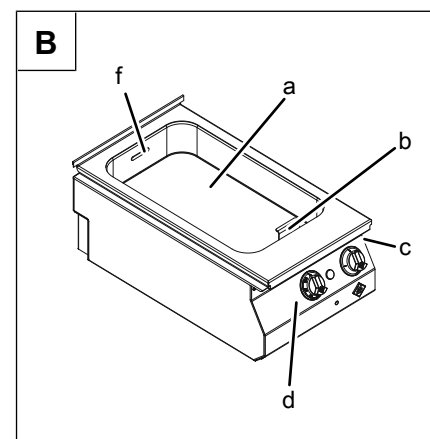
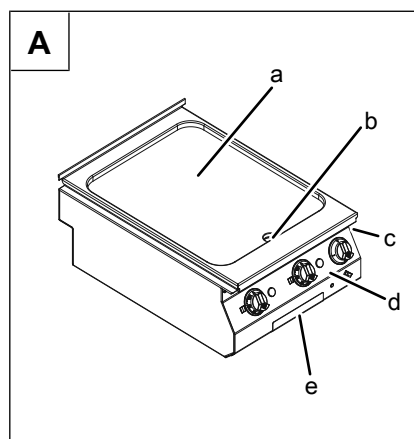

Image: A Griddle plate, B Griddle pan

- a Frying surface
- b Drain
- c Nameplate

- d Control panel
- e Collection container
- f *Maximum fill level mark*

3.1.3 Suspended unit

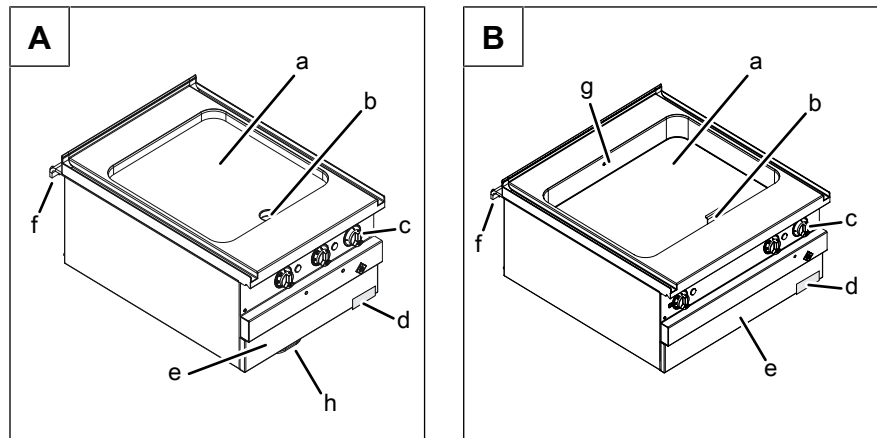



Image: A Griddle plate, B Griddle pan

- a Frying surface
- b Drain
- c Control panel
- d Nameplate
- e Installation duct cover panel
- f Suspension hooks
- g *Maximum fill level mark*
- h Collection container

3.2 Function of the operating and display elements

Operating/display element	Symbol	Designation	Function
On/Off control knob	0	Off	Switch off the unit
	1	On	Switch on the unit
Temperature control knob		Off	Heating element off
	50 — 300 °C	Temperature	Set the heating element; adjustable temperature
Heating indicator light			Illuminates, if the heating element is active

3.3 Operating temperature

Quantity	Temperature
Small to medium quantity	180 °C
Large quantity	200 — 220 °C

4 Operating the unit



CAUTION Risk of burns from hot surfaces

- Protect arms and hands by wearing suitable protective gloves.

4.1 Switching the unit on and off

4.1.1 Switching on

- Turn the *On Off* control knob to "1".
- ↳ The unit is now on.

4.1.2 Switching off

- Turn the *On Off* control knob to "0".
- ↳ The unit is now off.

4.2 Basic functions

4.2.1 Set the temperature

- Set the *temperature* control knob to the desired temperature.
 - ↳ The *heating* indicator light illuminates.
 - ↳ The *heating* indicator light goes out when the set temperature is reached.

4.3 Burning-in a frying surface made of steel



A frying surface made of steel must be burnt-in before being used for the first time.

It is not necessary to burn-in a frying surface made of stainless steel.

Do not use margarine or butter to burn-in a frying surface.

Requirements Collection container inserted

1. Set the temperature to approximately 250 °C.
 - ↳ The frying surface is heated.
2. After the set temperature has been reached, brush the frying surface thinly with commercially available frying oil.
3. Leave the frying surface to burn-in, until the surface is lightly browned.
4. Switch off the unit.
 - ↳ The frying surface cools down.

5. After it has cooled down, clean the frying surface with a stainless steel spatula and kitchen paper.

↳ Repeat the burning-in process two to three times.

4.4 Frying

ATTENTION

Risk of physical damage from extremely abrupt cooling

Extremely abrupt cooling deforms the frying surface

- Do not place any frozen food to be cooked on the hot frying surface.
-

Requirement Frying surface cleaned
Collection container used

1. Close the drain.
2. Switch the unit on.
3. Set the temperature.
↳ The frying surface is heated.
4. After the set temperature has been reached, brush the frying surface thinly with frying fat or oil.
5. Place the food to be cooked on the hot frying surface.
6. Free the frying surface of frying residue after you have finished each frying process (see "Cleaning and caring for the unit").

4.5 Braising



CAUTION

Risk of scalding from food that is cooking

Do not exceed the *maximum fill level* mark

Requirement Frying surface cleaned
Collection container used

1. Close the drain.
2. Load in the food to be cooked and observe the *maximum fill level* mark.
3. Switch the unit on.
4. Set the temperature.
5. Stir occasionally during cooking.

4.6 Emptying the collection container



CAUTION

Risk of scalding from hot liquids

- Allow the collection container to cool down before emptying it.
- Protect arms and hands by wearing suitable protective gloves.

ATTENTION

Risk of physical damage from congealing fat

Blockage of wastewater line and floor gutter is possible

- Do not empty the collection container with liquid fat into the sink or floor gutter.

1. Close the drain of the frying surface.
2. Remove the collection container carefully from the unit and empty it properly.
3. Remove the frying residue and wipe the collection container out with kitchen paper.
4. Insert the empty collection container.

4.7 Pausing and end of use

Switch off the unit during pauses and at end of use.

4.7.1 Short pause

Requirements The unit is on
Food being cooked has been removed from the frying surface

→ Turn the *Temperature* control knob to .

↳ The *Heating* indicator light goes out.

4.7.2 Longer pause and end of use

Requirements The unit is on
Food being cooked has been removed from the frying surface

1. Turn the *Temperature* control knob to ".

↳ The *Heating* indicator light goes out.

2. Turn the *On/Off* control knob to "0".

↳ The unit is now off.

5 Cleaning and caring for the unit



CAUTION

Risk of burns from hot surfaces

- Allow surfaces to cool prior to cleaning.
-

ATTENTION

Risk of physical damage from extremely abrupt cooling

- Do not cool shock the unit by cooling it abruptly.
-

ATTENTION

Risk of physical damage from improper cleaning

- Do not clean the unit with a high-pressure cleaner or water jet.
-

5.1 Preventing corrosion

- Keep the surfaces of the unit clean and with access to air.
- Remove lime, grease, starch and protein deposits.
- Only expose parts made from non-rusting steel to brief contact with highly acidic foods, spices, salts or the like.
- Avoid damaging the stainless steel surface with other metal items, for example steel spatulas or steel wire brushes.
- Prevent contact with iron and steel, for example steel wool and steel spatulas.
- Do not use bleaching or chlorine-containing cleaning agents.
- Clean contact surfaces with water.

5.1.1 Protecting a frying surface made of steel

A frying surface made of steel will corrode, if the burnt-in surface is damaged. This is not a deficiency in the unit but rather a characteristic of a frying surface made of steel.

- Ensure that the burnt-in surface is not damaged by cleaning or use.
- Do not use any scraping objects for cleaning.
- After intensive cleaning has been completed, repeat the burning-in process.

Tip

In order to care for the rust protection, or if it has been worn away, apply a special care product or thin oil film.

5.2 Removing rust spots

- Remove fresh rust spots with a mild abrasive or fine sandpaper.
- Always remove rust spots completely.
- Expose treated areas to fresh air for at least 24 hours. During this time, do not allow any contact with greases, oils or foods so that a new protective layer can form.

5.3 Cleaning the housing

ATTENTION

Risk of physical damage from improper cleaning

- Do not clean the housing with highly abrasive or chemically aggressive cleaning agents.
- Do not clean the housing with highly abrasive sponges.

Requirement Unit switched off and cooled down

→ Clean the housing with warm water and commercially available washing-up liquid.

5.4 Cleaning the frying surface between cooking processes



CAUTION

Risk of burns from hot surfaces

- Protect arms and hands by wearing suitable protective gloves.

The frying surface must be cleaned of frying residue between the frying processes.

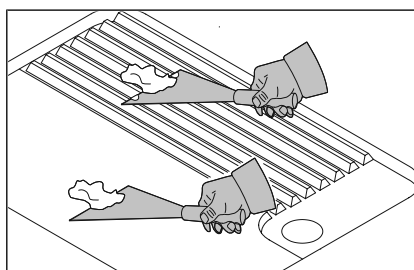

Image: Smooth and rippled frying surface

1. Clean the smooth frying surface with a smooth scraper. Clean the rippled frying surface with a rippled scraper.
2. Remove the loosened frying residue with kitchen paper.

5.5 Cleaning the frying surface



CAUTION

Risk of burns from hot surfaces

- Allow surfaces to cool prior to cleaning.



Remove stubborn frying residue when the frying surface is still warm (approx. 60 °C).

If there is heavy residue, clean the frying surface with a special stainless steel sponge (e.g. Spontex Spirinett) between cleaning.

Requirement Frying surface cooled down

1. Insert the empty collection container.
2. Pour warm water and mild cleaning agent onto the frying surface.
3. Allow this to soak in for several minutes.
4. Let the cleaning water drain away.
5. Empty the collection container and insert it again.
6. Clean the frying surface with a stainless steel spatula or stainless steel sponge.
7. Rinse with clear water and then dry.
8. Clean and dry the drain and drain pipe thoroughly with a bottle brush.
9. Grease the frying surface lightly with frying fat.
10. Empty the collection container.

Tip

Dry the frying surface by heating it briefly.

5.6 Cleaning the drain

Requirements Unit switched off and cooled down

Frying surface cooled down

Frying surface cleaned

Empty collection container inserted

1. Clean the drain and discharge pipe thoroughly with a bottle brush.
2. Clean the drain and discharge pipe with clear water.
 - ↳ Use a mild cleaning agent if required.
 - ↳ Rinse thoroughly with clear water.
3. Wipe dry with a lint-free cloth.
 - ↳ Ensure that no water remains in the drain.
4. Empty and clean the collection container (see "Cleaning and caring for the unit").

5.7 Cleaning the collection container

Requirement Collection container cooled down and emptied

1. Remove the collection container from the unit.
2. Remove the frying residue and wipe the collection container out with kitchen paper.
3. Clean it with clear water and mild cleaning agent.
4. Dry the collection container and insert it again.

6 Troubleshooting

6.1 Cause of failure and the remedy

Failure	Possible causes	Remedy
The unit does not react	Operating element is defective	<ul style="list-style-type: none"> • Disconnect the unit from the electric mains. • Contact Customer service.
The unit does not heat up	Unit is defective	<ul style="list-style-type: none"> • Disconnect the unit from the electric mains. • Contact Customer service.
	Power supply interrupted	<ul style="list-style-type: none"> • Contact the authorized technical personnel.
	<i>Output</i> control knob or heating element is defective	<ul style="list-style-type: none"> • Disconnect the unit from the electric mains. • Notify Customer service.
	The unit is switched off	<ul style="list-style-type: none"> • Switch the unit on.
	<i>Output</i> control knob on "△" setting	<ul style="list-style-type: none"> • Set the output.
Insufficient heat output	Unit is defective	<ul style="list-style-type: none"> • Disconnect the unit from the electric mains. • Contact Customer service.
	Mains phase missing	<ul style="list-style-type: none"> • Contact the authorized technical personnel.

6.2 Nameplate

When contacting Customer service, please always provide the following data from the nameplate:

Serial number (SN)	
Type number (TYP)	

7 Carrying out maintenance

The unit is maintenance-free, there are no maintenance requirements.

8 Disposal in an environmentally responsible manner

Do not dispose of unit or the unit's components together with non-recyclable waste. If the unit is disposed of together with non-recyclable waste or treated improperly, toxic substances contained in the unit can damage health and pollute the environment.

Dispose of the unit in accordance with local regulations for used appliances. Clarify any open questions with the responsible agencies (for instance, solid waste management).

Oil and fat Residue that contains oil and fat must be collected in suitable containers and disposed of in accordance with the local disposal regulations.

Cleaning agents Dispose of leftover cleaning agents and cleaning agent containers in accordance with the information provided by the cleaning agent's manufacturer. Observe applicable regional regulations.

Unit In addition to valuable materials, used electrical and electronic equipment also contains harmful substances that were needed for their operation and safety.

9 Manufacturer's declaration



EC Declaration of Conformity



Manufacturer

MKN Maschinenfabrik Kurt Neubauer GmbH & Co. KG • Halberstädter Straße 2a • 38300 Wolfenbüttel, Germany

We hereby declare, that the following product:

Description of the unit							
Unit for cooking food in commercial applications							
Unit type							
Electric griddle pan							
Unit number							
0722507	0722509	0722513B	10013254	10013255	10013256	10013257	10017558
1222507	1222509	1322507	1322509	1422507	1422509	1422513B	1422515B
1522507	2022507	2022509	2122507	2122509	3022507	3022509	

complies with the relevant provisions of the following directives and regulations, but does not contain any assurance of properties:

- Directive 2011/65/EU (RoHS) dated 01 July 2011
- Directive 2014/30/EU dated 26 February 2014 on electromagnetic compatibility
- Directive 2014/35/EU dated 26 February 2014 on electrical equipment used within certain voltage limits
- REGULATION (EC) No. 1935/2004 dated 27 October 2004 on materials and objects, which are intended to come into contact with food

Adduced basis for verification
EN ISO 12100:2010
DIN EN 55014-1:2012-05
EN 60335-1:2012
EN 55014-2:2015
EN 60335-2-38:2003/AC:2007

The manufacturer bears the sole responsibility for issuing this Declaration of Conformity. This Declaration of Conformity becomes invalid, if changes are made which are not agreed with us.

Translation from the original document • 2022507--0KODE-B

Wolfenbüttel, 11/01/2018

Person authorised to compile the technical documents:

ppa. Peter Helm, Chief Technical Officer (address as manufacturer)





EC Declaration of Conformity



Manufacturer

MKN Maschinenfabrik Kurt Neubauer GmbH & Co. KG • Halberstädter Straße 2a • 38300 Wolfenbüttel, Germany

We hereby declare, that the following product:

Description of the unit
Unit for cooking food in commercial applications

Unit type
Electric griddle pan

Unit number							
0722507	0722509	0722513B	10013254	10013255	10013256	10013257	10017558
1222507	1222509	1322507	1322509	1422507	1422509	1422513B	1422515B
1522507	2022507	2022509	2122507	2122509	3022507	3022509	

complies with the relevant provisions of the following directives and regulations, but does not contain any assurance of properties:

- Directive 2011/65/EU (RoHS) dated 01 July 2011
- Directive 2014/30/EU dated 26 February 2014 on electromagnetic compatibility
- Directive 2014/35/EU dated 26 February 2014 on electrical equipment used within certain voltage limits
- REGULATION (EC) No. 1935/2004 dated 27 October 2004 on materials and objects, which are intended to come into contact with food

Adduced basis for verification
EN ISO 12100:2010
DIN EN 55014-1:2012-05
EN 60335-1:2012
EN 55014-2:2015
EN 60335-2-38:2003/AC:2007

The manufacturer bears the sole responsibility for issuing this Declaration of Conformity. This Declaration of Conformity becomes invalid, if changes are made which are not agreed with us.

Translation from the original document • 2022507--0KODE-B

Wolfenbüttel, 11/01/2018

Person authorised to compile the technical documents:

ppa. Peter Helm, Chief Technical Officer (address as manufacturer)



www.mkn.eu

